



PJM Straw Proposal: Ancillary Services for “Net Excess” DER Behind a Customer Meter

Andrew Levitt

August 27, 2018

Senior Business Solutions Architect,
Applied Innovation

- Treatment of positive and negative power for Ancillary Services from PJM generators located behind a customer meter
- Ancillary service assignment quantities:
 - Remove current logic that links energy market parameters (like ECOMIN) to Ancillary Service quantities
 - Responsibility on market participant to ensure that the cleared Ancillary Services quantities are achievable given physical constraints and competing services
- Performance measurement:
 - For Synch Reserve—consider both positive and negative values at the Point Of Interconnection (POI) meter
 - For Reg—either POI (both positive and negative) or gen submeter plus telemetered basepoint
- Generator submeter required to audit “on” status
- Must offer the gen headroom capability not offered for energy in Synch Reserve Market

PROPOSAL FOR INFLEXIBLE SYNCHRONIZED RESERVES

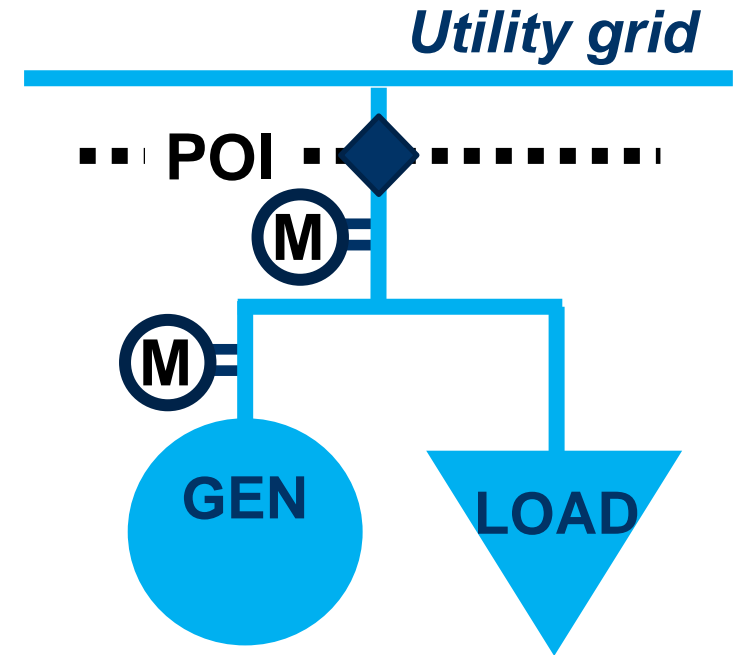

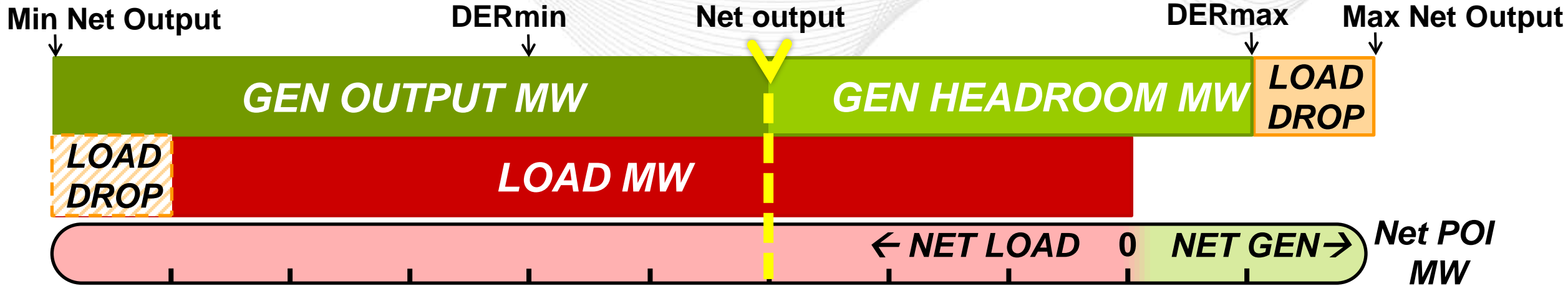

Term	Definition
Min Net Output	Lowest MW value the POI meter would read when the Gen is offline
DERmin	Minimum gross MW the generator must operate at when online
DERmax	The maximum gross MW capacity of the generator
Gen headroom	Difference between the DERmax and the current generator output
DER dispatchable range	The difference between DERmax and DERmin
SR capability range	Maximum range of MW from the generator headroom plus load drop that can be offered into the SR Market

Synch Reserve Proposal: Before Spin Event

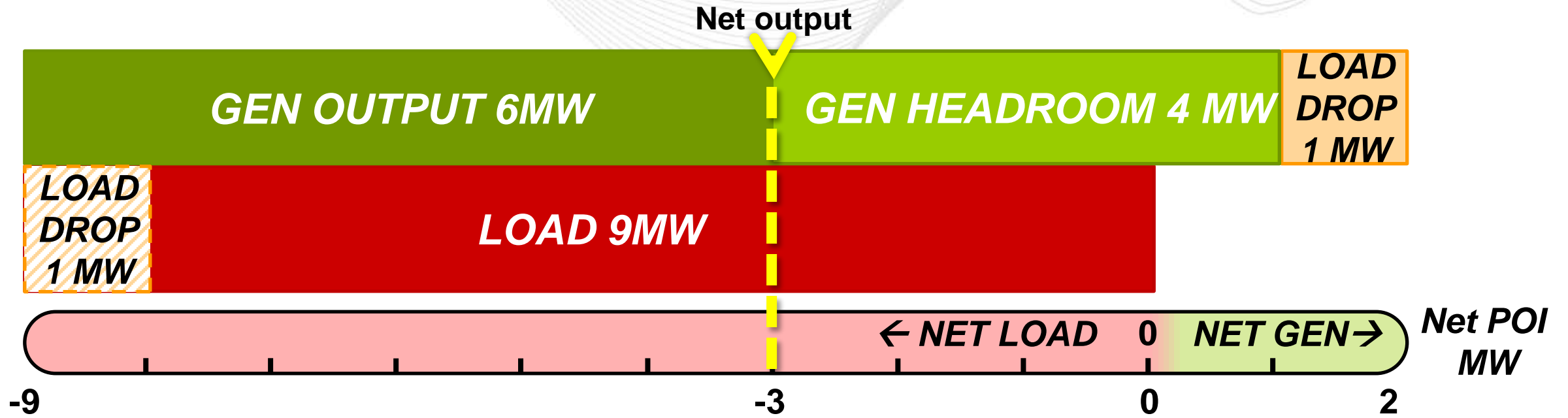

Current POI meter reads -3 MW

Synch Reserve Proposal: During Spin Event

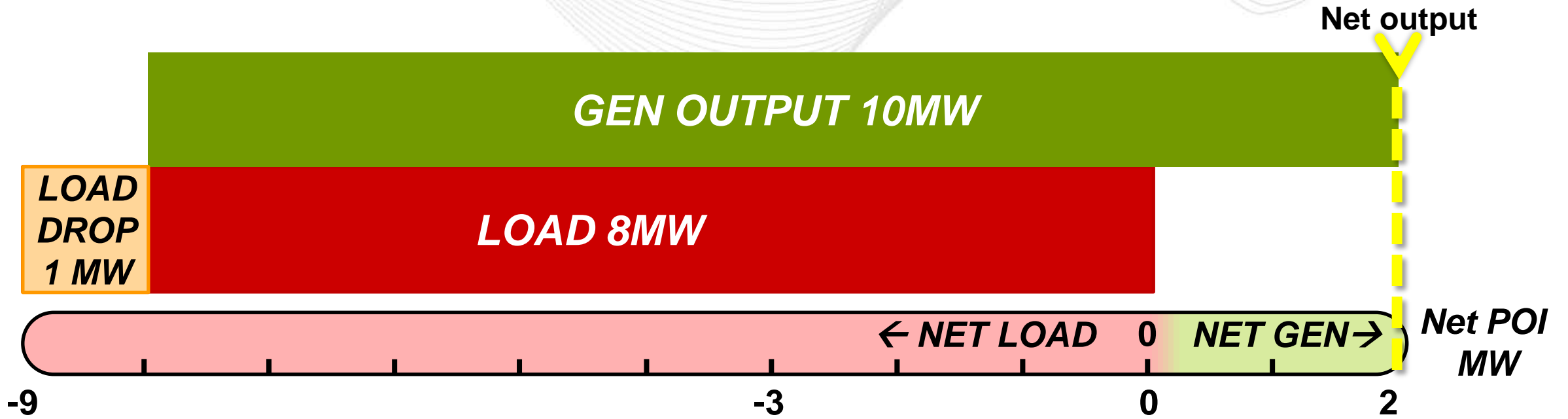

Current POI meter reads +2 MW

Proposal: Allow SR Capability Below Ecomin

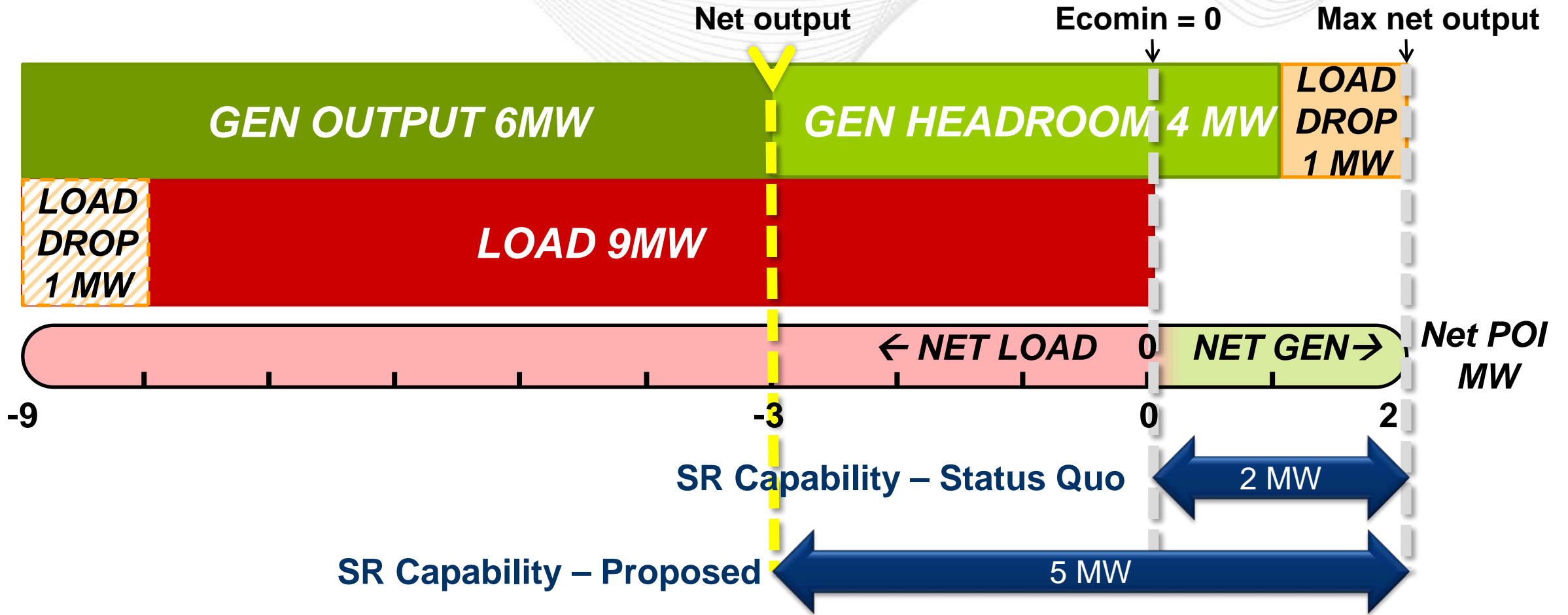

Does the Resource Need to Be Synchronized?

- Synch Reserve capability is measured as the sum of:
 - (1) Generator headroom and (2) ability to physically curtail or “drop” load
- Load curtailment is assumed to always be synchronized
- Generator must be synchronized if any SR assignment MW come from the generator
- PJM requires interval submeter on generator and reserves the right to ex-post audit

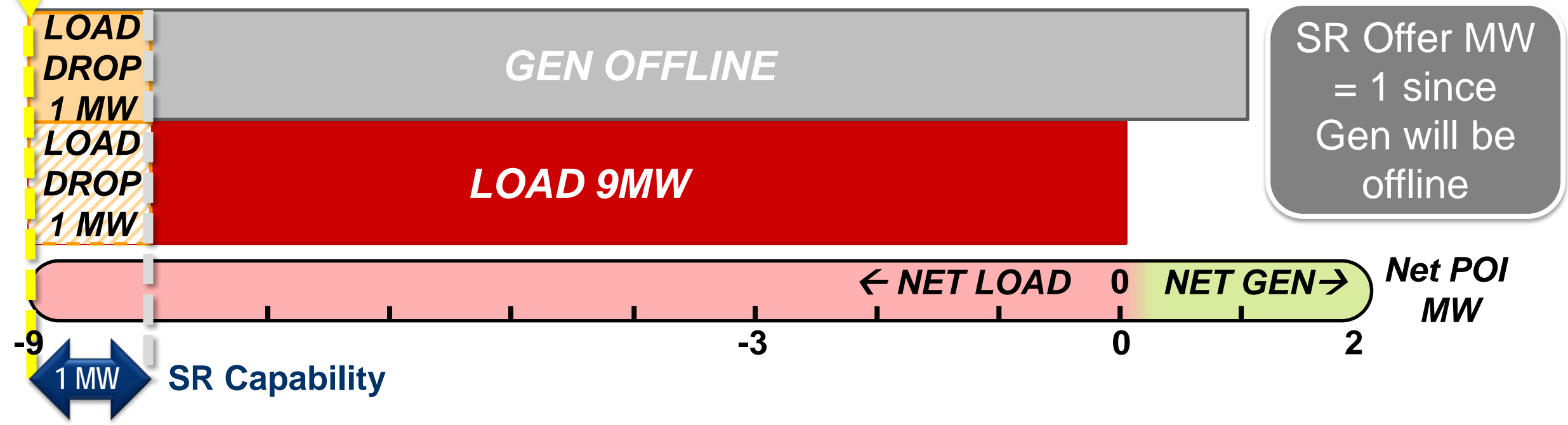

- No PJM co-optimization or Lost Opportunity Cost (LOC)
- Ramp will not be used as part of capability evaluation
- DER will offer SR MW quantity and price into SR Market
- DER will be responsible for managing energy and SR offers to avoid conflicts & meet physical limits
 - Assigned SR MW should not be offered into the Energy Market
 - DER required to offer SR commensurate with gen headroom + available load drop & desired energy market availability.
- PJM will implement logic to ensure that SR assignment + energy offer quantity \leq total registered capability (gen dispatchable range + load drop)

SR and Energy Offer Quantity Limit Logic

- **Registered Max Flexible Range** = Total generator dispatchable range + registered load drop
- SR offers limited to the Max Flexible Range
- Current Energy Market participation limited to the range above Net POI = 0 (positive values)

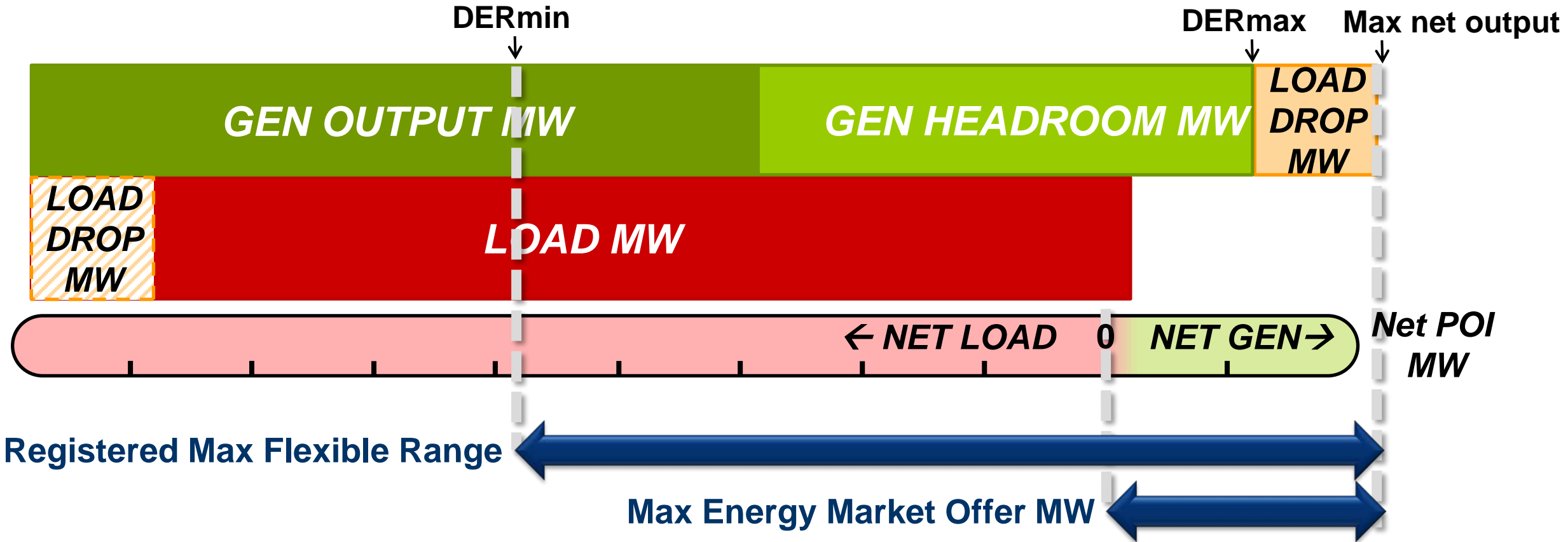

Status quo: online, non-emergency **capacity** generators must offer 90% of the ramp limited quantity into the Synchronized Reserve Market. DR is currently exempt from the SR must offer requirement.

Proposal for DER: must offer requirement will apply to DER with capacity obligation (cleared in RPM)

- Specific amount of must offer MW to be determined

- Telemetry required at the Point Of Interconnection (status quo)
- SR performance includes positive and negative numbers
- Use status quo for non-performance penalties
 - Clawback the amount of non-performance MW at the SRMCP the day of the event
 - Retroactive compensation refund for every hour cleared in the past 19 days (or since last non-performance, whichever is less)

- DER is excluded from Tier I
 - Because PJM not using ramp rate
 - Because PJM not monitoring load offset capability in real time
- Market Participant responsible for offering into the Synchronized Reserve Market only when the resource is online and synchronized
 - PJM requires interval submeter and reserves the right to ex-post audit
- Process for registration of load curtailment portion of DER similar to existing Demand Resource load curtailment qualification process

PROPOSAL FOR REGULATION

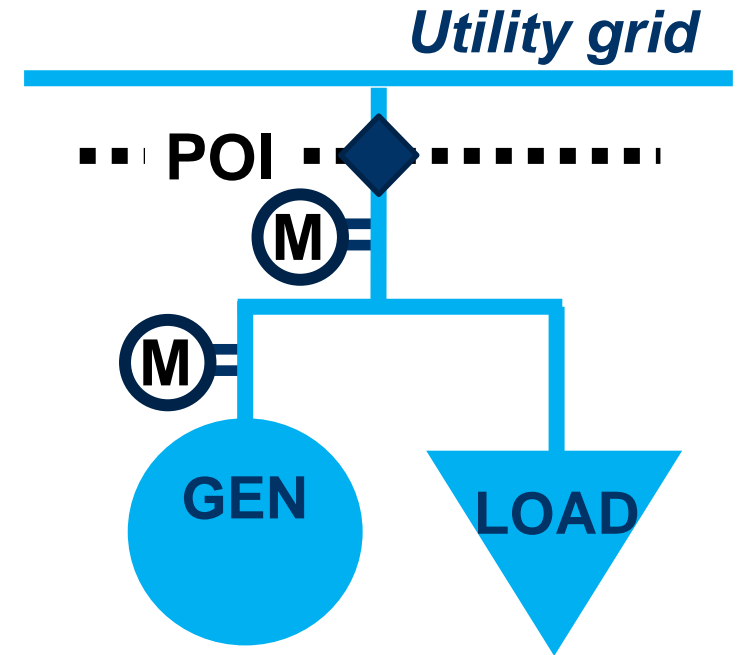

Proposal: Allow RegLo Below Ecomin

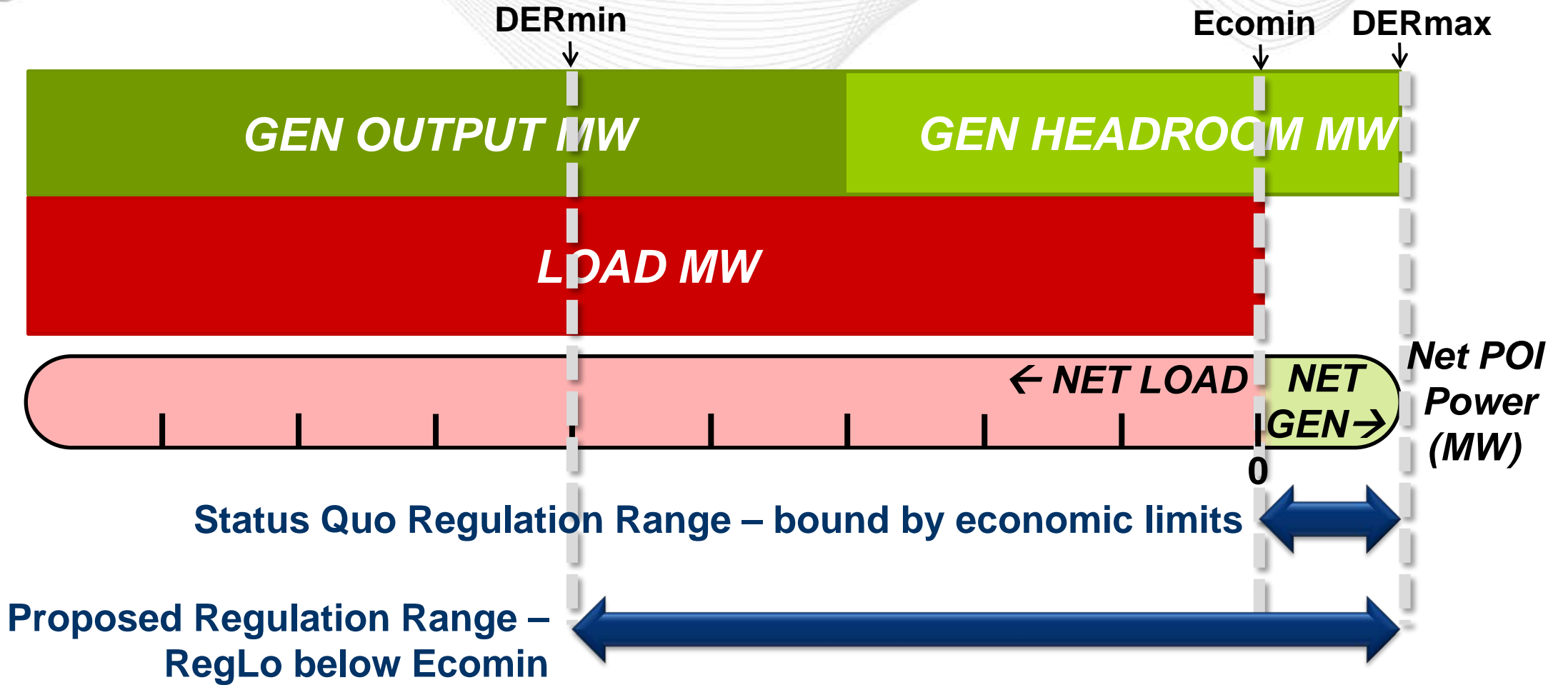

- No co-optimization of Regulation and energy
 - No LOC will be calculated
- Will allow the RegLo limit to go below ecomin
 - DER is responsible for ensuring that the MW amount offered into Regulation is achievable considering the DER's operating parameters (ie: DERmin, DERmax, dispatchable range, desired net operating basepoint)

- Provide option to directly measure the generator performance at a submeter
 - Allows uncontrolled load to float around without impacting performance score
- Real-time telemetry at submeter
- Basepoint telemetered to PJM (similar to Demand Response)

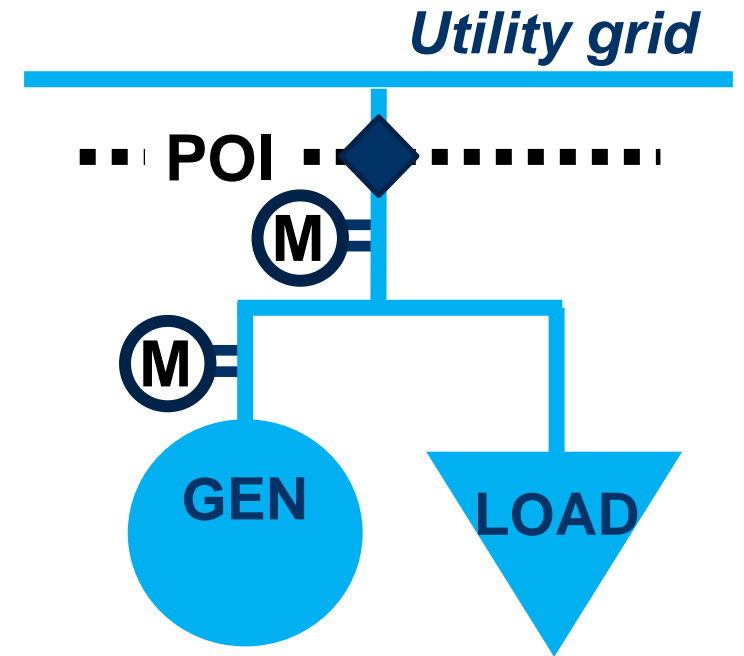

SUBMETER PROPOSAL

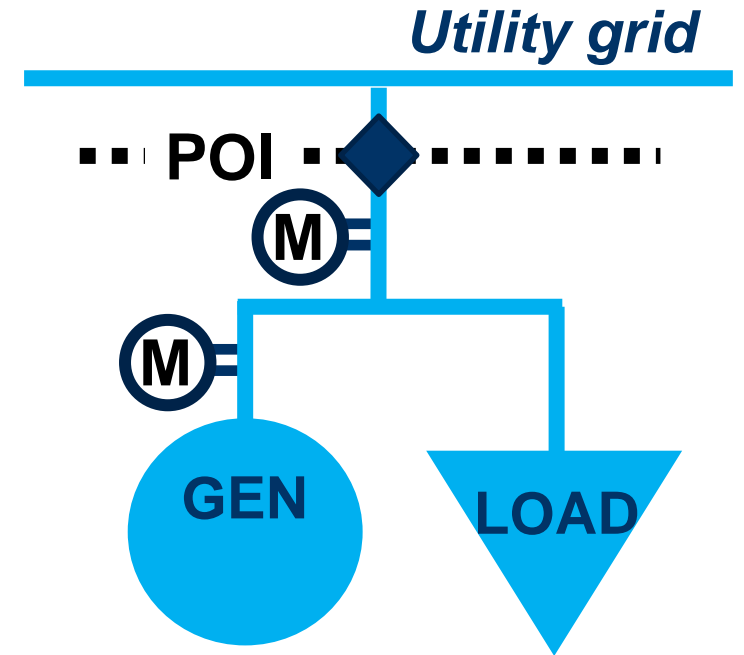

	<i>Design Component</i>	<i>Status Quo</i>	<i>PJM Proposal</i>
4.1	Submeter ownership	Third party ownership of POI meters allowed for PJM generators.	Third party submeter allowed as per Demand Response status quo for Regulation submeter
4.2	Submeter communications	PJMNet ICCP or Jetstream DNP3 depending on size. Via marketer or TO as Market Operations Center.	Status Quo
4.3	Submeter set-up Process	N/A	Similar to Regulation performance testing