

# SRRTEP Committee: Western DLC Supplemental Projects

June 19, 2020

# Needs

Stakeholders must submit any comments within 10 days of this meeting in order to provide time necessary to consider these comments prior to the next phase of the M-3 process

**Need Number:** DUQ-2020-001

**Process Stage:** Needs Meeting 06/19/2020

**Project Driver:** Infrastructure Resilience.

**Specific Assumptions Reference:** DLC 2020 Local Planning Assumptions (Slide 9).

**Problem Statement:**

Various landslides were found along the 138 kV transmission circuits Dravosburg – Carson (Z-71) and Carson – Bettis (Z-88) affecting towers #3640, #3641, #3642, and #3643.

Due to the landslide close proximity to the towers, transverse cracking, and the geological weak soil layers, the existing towers are expected to be vulnerable to movement which can compromise their structural integrity.

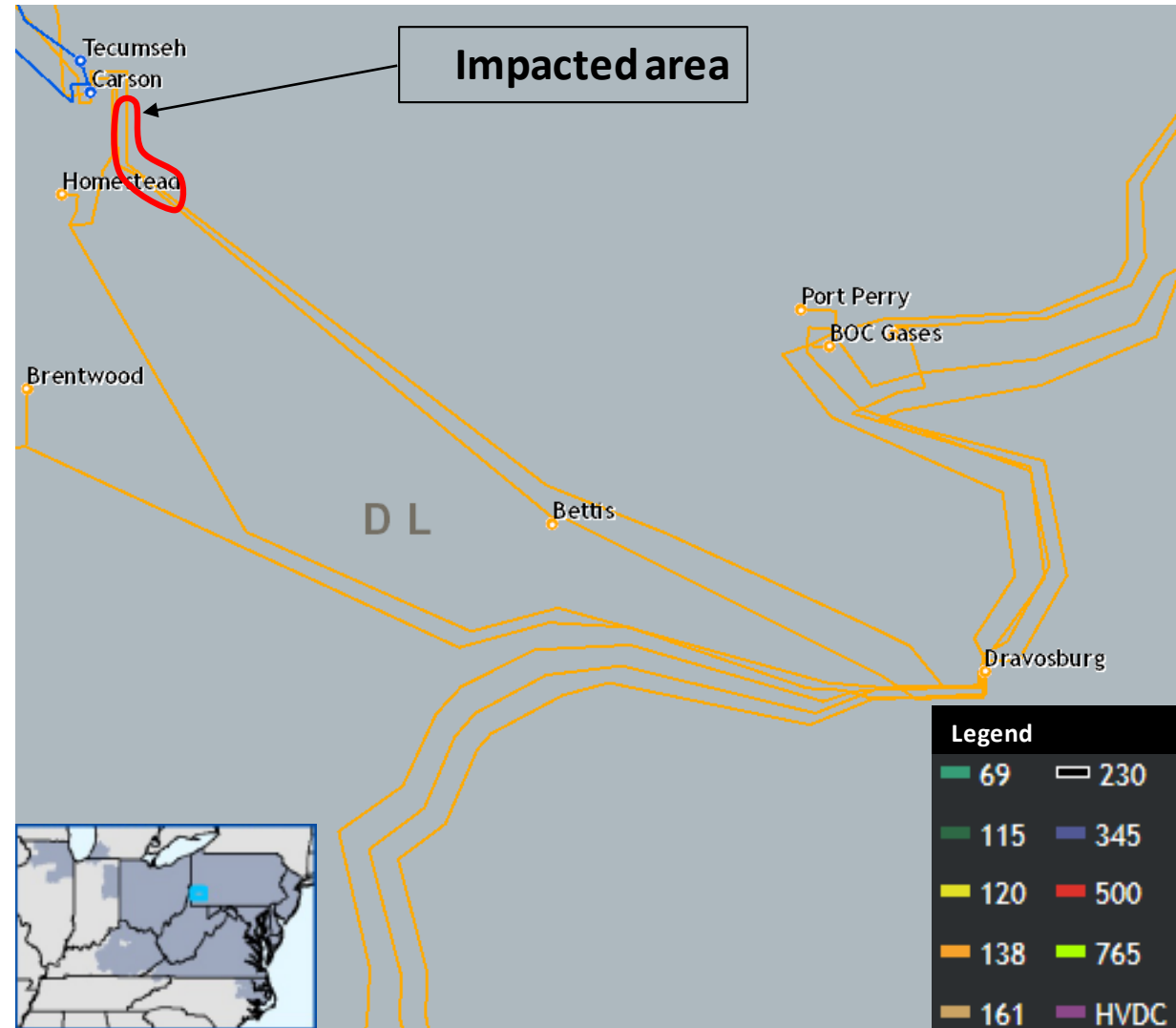

# Solutions

Stakeholders must submit any comments within 10 days of this meeting in order to provide time necessary to consider these comments prior to the next phase of the M-3 process

**Need Number:** DUQ-2019-001

**Process Stage:** Solutions Meeting 6/19/2020

**Previously Presented:** Needs Meeting 2/20/2019

**Project Driver:** Customer Service.

**Specific Assumptions Reference:** Pennsylvania Turnpike Commission Expressway Expansion Project to Encroach Existing Transmission Right of Ways.

**Problem Statement:**

The Pennsylvania Turnpike Commission (PTC) has informed Duquesne Light Company (DLC) that it plans to construct an expressway from Jefferson Hills Borough to I-376 in Monroeville. The initial construction phases of this expressway begin in Jefferson Hills and end in the city of Duquesne. The construction of this expressway will closely follow the DLC transmission corridor between the Wilson and Port Perry transmission stations and, as such, a number of DLC’s existing transmission structures will be impacted and/or displaced.

The PTC has requested that all DLC modifications are completed prior to the start of the corresponding expressway construction phase, the last of which is 3/31/2023.

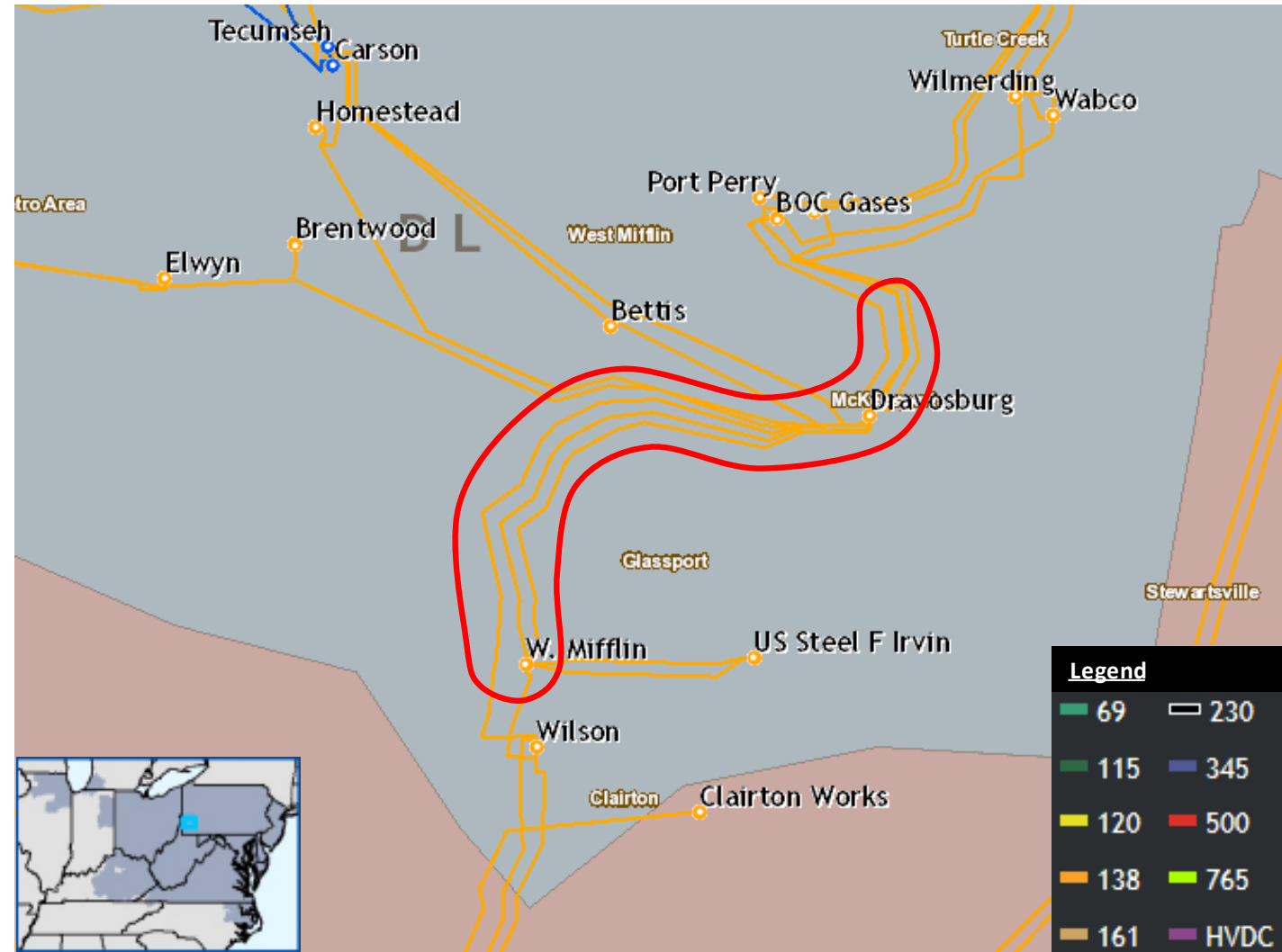

# DLCO Transmission Zone M-3 Process Monroeville, PA

**Need Number:** DUQ-2019-001

**Process Stage:** Solutions Meeting 6/19/2020

**Proposed Solution:**

Relocate 56 transmission structures and approximately 13.9 circuit miles of conductor in order to reroute the affected circuits in three (3) different areas along the Wilson to Port Perry transmission corridor.

**Alternatives Considered:**

No feasible alternatives exist for this project.

**Estimated Cost:** \$0 (All project costs will be reimbursed by the PTC).

**Projected In-Service:** 3/31/2023

**Project Status:** Engineering

**Model:** 2019 Series RTEP

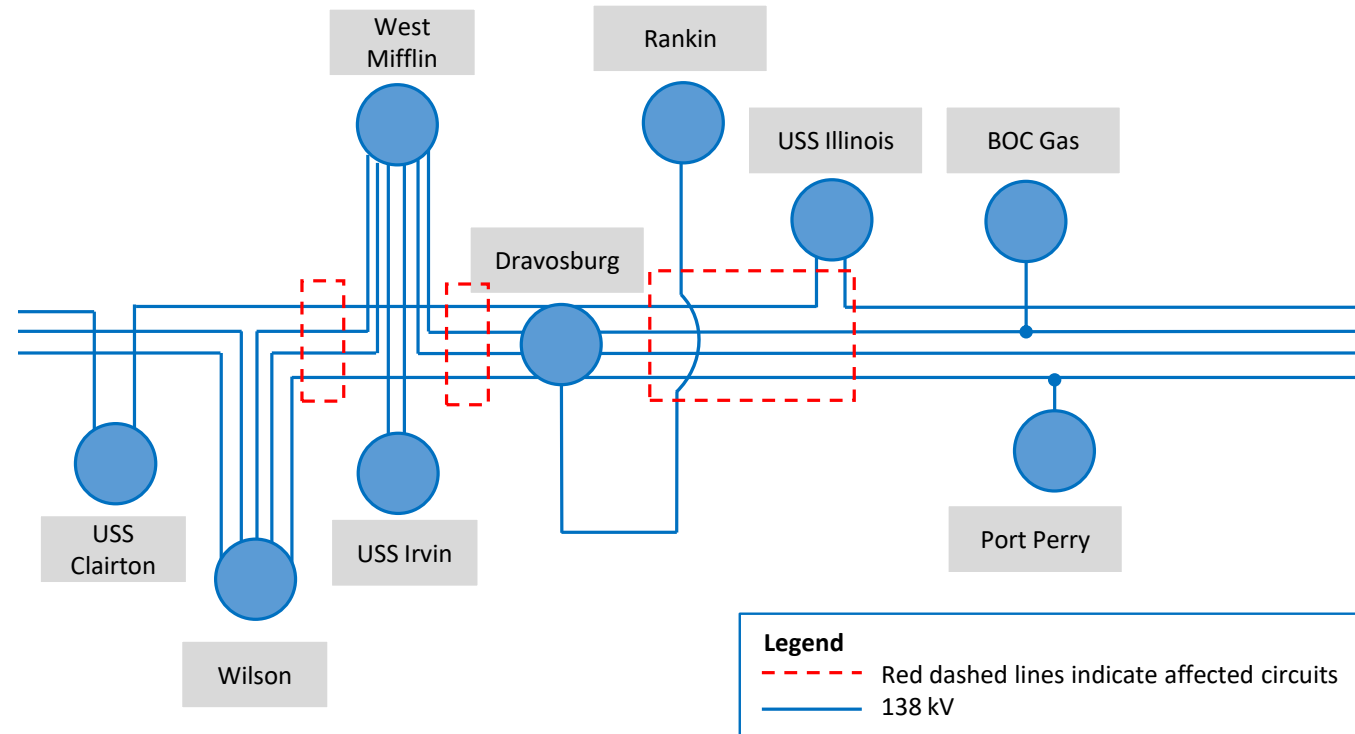

# Appendix

# High Level M-3 Meeting Schedule

Assumptions	Activity	Timing
	Posting of TO Assumptions Meeting information	20 days before Assumptions Meeting
	Stakeholder comments	10 days after Assumptions Meeting
Needs	Activity	Timing
	TOs and Stakeholders Post Needs Meeting slides	10 days before Needs Meeting
	Stakeholder comments	10 days after Needs Meeting
Solutions	Activity	Timing
	TOs and Stakeholders Post Solutions Meeting slides	10 days before Solutions Meeting
	Stakeholder comments	10 days after Solutions Meeting
Submission of Supplemental Projects & Local Plan	Activity	Timing
	Do No Harm (DNH) analysis for selected solution	Prior to posting selected solution
	Post selected solution(s)	Following completion of DNH analysis
	Stakeholder comments	10 days prior to Local Plan Submission for integration into RTEP
	Local Plan submitted to PJM for integration into RTEP	Following review and consideration of comments received after posting of selected solutions



# Revision History

6/9/2020 – V1 – Original version posted to pjm.com